

Solar Power for PC Deployments: Enabling ICT Beyond the Grid



Technology for converting solar energy to electricity was first introduced over 130 years ago, and it has been used to power PCs for more than 20 years. However, until recently it has been prohibitively expensive to use solar energy to power PCs in areas where the electric grid is not available: energy-hungry PCs simply put too much demand on the limited generation capabilities of the solar panels. Yet even as computers have become much more energy efficient in recent years, many people still perceive solar energy as being too expensive for PC deployments.

In this paper we will explain the technological changes that have made solar power cost feasible for PC deployments, and provide an overview of how to design for a solar powered PC deployment. The objective of this paper is not to replace the need for an experienced solar installer; rather, it is to provide basic knowledge to help the reader prepare a budget for a solar deployment, and to be able to effectively communicate the requirements to an installer.

Introduction

World production of photovoltaic panels has increased by several orders of magnitude in the past decade, reducing their cost by nearly 50% over the last ten years.¹ However, the primary reason that solar power has become feasible for PC deployments is the dramatic reduction in power consumption of modern, energy efficient PCs.

A few years ago, a typical desktop PC using a processor such as the Intel® Pentium® 4 Processor 2.8Ghz supporting Hyper-Threading technology consumed about 80W to 100W. A 15" CRT monitor consumed an additional 70W to 100W, so a complete PC desktop system used 150W to 200W.

By comparison, a modern netbook based on an Intel® Atom processor with a 10" screen consumes just 12W to 15W total. A laptop using an Intel® Celeron® M ultra low voltage (ULV) processor with a larger 13" wide screen display can consume as little as 20W to 25W. New power-efficient desktop designs offer similar improvements: the Inveneo* Computing station, for example, is based on the Intel® Atom™ processor D410 and consumes about 15W. Coupled with the Inveneo* energy efficient LCD display, the entire system consumes only about 22W.

Thus, a modern PC can provide a rich experience while consuming 90% less power of a typical desktop system of just a few years ago.

This is significant for solar deployments, whose cost increases linearly with the amount of electrical power required. In other words, doubling the amount of energy required in a day nearly doubles the cost of the necessary solar equipment.

Conversely, reducing the daily energy requirement by 60% will reduce the cost of the solar equipment needed by nearly 60%. Every watt of energy that that PCs don't use leads to significant reductions in the cost of solar equipment. Combined with the rise of energy efficient PCs, this means that organisations can now roll out more PCs with a smaller investment in solar power generation than ever before.

Table of Contents

Introduction 1

Powering PCs Where There Is No Power..... 2

How a Solar Panel System Works . . 3

 Solar Components3

Designing a power efficient solar deployment 4

 Solar Insolation4

 Panel Ratings.....4

Design Steps 5

 Load Calculation5

 System Sizing.....6

 Solar Panels.....6

 Battery6

 System Design.....6

Deployment Considerations..... 7

Summary..... 7

Powering PCs Where There Is No Power

When energy efficient ICT equipment is paired with appropriate solar panels, PCs and related devices can be introduced into areas where unreliable or non-existent power supplies have previously limited access to technology. In many cases, this means remote villages in developing countries are now able to access community amenities and life-enhancing benefits such as rural health care clinics, communal telecenters, and school PC laboratories.

A common application of solar power is that of supplying electricity for rural school PC labs. This was the goal at Tenua High School, a semi government high school in Netrokona, Bangladesh – about five to six hours’ drive from the capital, Dhaka. The co-educational school has around 360 students that come from the surrounding community – which, like the school, has no access to electricity.

Even though fewer than 5% of the students had ever touched a PC, all of them are fully aware that ICT literacy is important for their futures. However, without appropriate infrastructure and resources, it was impossible for the school to provide training to develop those skills.

To bring them the technology they needed, Intel teamed up with PowerCom, a local solar system installer, to design an extremely power efficient solar PC lab. Four solar panels were installed, providing sufficient energy to power 10 Intel® powered classmate PCs for an average of five hours per day. In addition, energy efficient lights provide an electric light source after dark.

D.Net, a local NGO that operates the school, provided in-depth ICT training to two teachers so they could train the students effectively. The impact was nearly immediate, with the principal reporting an increase in student attendance and enrolment: making ICT available to students boosted their desire to learn.



How a Solar Panel System Works

It may surprise many people that a few solar panels can provide enough power to support ICT-enhanced educational opportunities for an entire school.

Although solar energy solutions may seem high-tech and complicated, the solution is relatively simple and does not involve many components. Figure 1 shows the schematic diagram of a typical solar deployment.

Solar panels (also called photovoltaic panels) utilize the chemical properties of specially-prepared silicon to capture the energy from sunlight and convert it into electricity. The panels are connected to a deep-cycle battery via a charge controller, whose main function is to regulate the power flowing from the solar panels into the battery.

The charge controller prevents overcharging of the battery: once the battery is fully charged, the controller prevents further charging as this would damage the battery. It also generally contains a low-charge disconnect. If the charge of the battery drops below a

pre-determined level, it disconnects the "load" to preserve the life of the battery. Commonly, the controller also protects against faults such as reverse connections of panels, battery or load equipment.

Energy is stored in deep cycle batteries, which look like ordinary batteries found in automobiles. However, there are important differences: whereas an automotive or 'starter' battery provides an occasional short powerful burst of energy to start a car, deep cycle batteries are designed to provide constant power over a long period of time, discharging and recharging every day.

Electrical equipment, often referred to as "load", is connected via the charge controller to the deep cycle battery. Photovoltaic panels produce direct current (DC) and batteries store DC, so the generated power can be fed directly into the batteries without conversion.

Use of DC also makes solar power particularly appropriate for high-tech equipment, since this is what PCs use for their internal operations. Even where PCs are plugged into an alternating current

(AC) wall socket, they incorporate a power supply to convert AC to DC for use inside the device. Such devices - as well as devices designed for direct DC connection, such as the Inveneo* Computing Station - can run directly on 12 Volt DC power. Where other equipment requires AC power, an inverter converts DC into AC.

Solar Components

Figure 2 shows the components of a typical solar deployment powering a single netbook. In this photo, the netbook is powered through the inverter, which draws its energy from the deep cycle battery. The inverter is connected via a small charge controller that sits between the battery and solar panel for load protection. Large off-grid deployments work similarly to this very small deployment, but use larger and multiple solar panels, batteries and charge controllers.

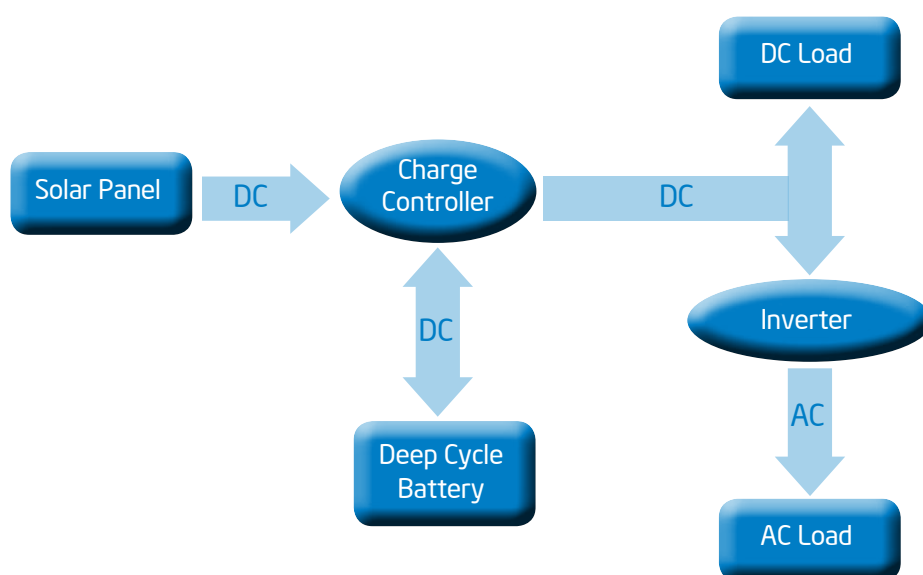

Figure 1. A general solar panel setup uses the charge controller to ensure optimal charging of a deep-cycle battery.

Designing a power efficient solar deployment

In order to design a solar system it is important to have a basic understanding of the physics behind photovoltaic and batteries.

Solar Insolation

The amount of solar radiation energy reaching the earth is known as solar insolation and is commonly expressed in kilowatt hours per square meter per day (kWh/m²/day). It varies by location and the time of year: for example, solar insolation is much higher in desert regions around the equator than in Northern Europe. Figure 3 shows a high-level map of solar insolation values around the world.

There are many resources available on the Web which list the solar insolation values for different areas; experienced solar installers will be well aware of solar insolation factors in your area.²

Panel Ratings

Solar panels are rated in terms of watt-peak (W_{peak}), which represents the amount of electrical power the panel produces under standardized conditions. The actual amount of power produced by a solar panel per day depends on factors like the duration of sunlight during the day, position and angle of the panels towards the sun, cloud cover, and others affecting the intensity and quality of available light.

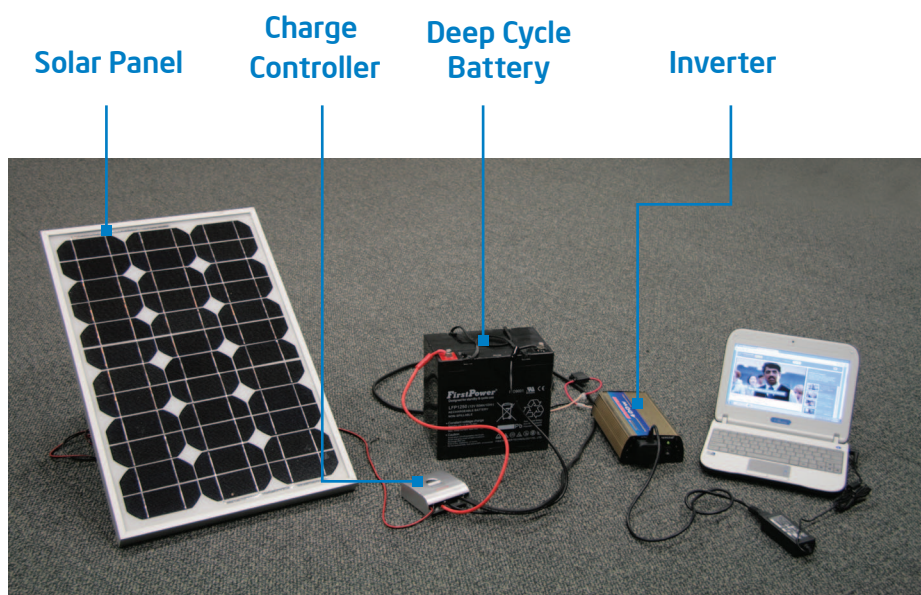

Figure 2. Components of a solar panel system.

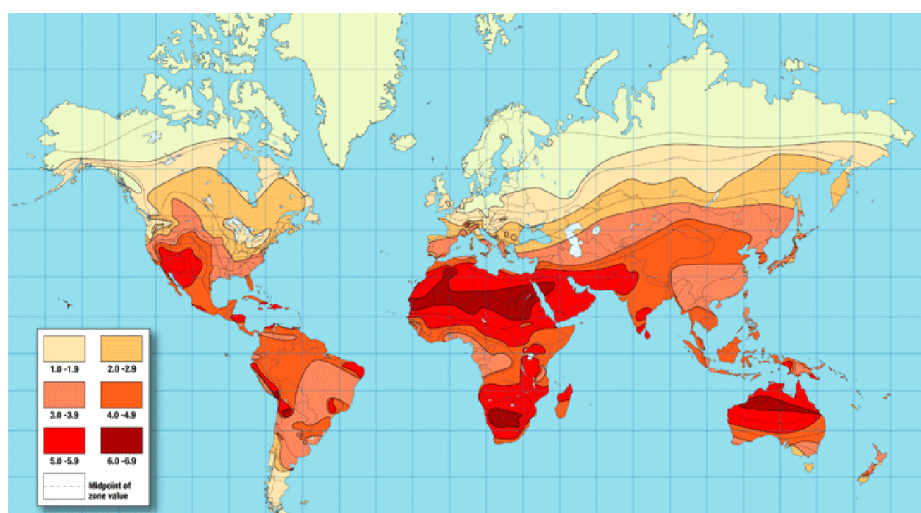

Figure 3. High-level map of solar insolation values around the world.

To approximate the total output per day in terms of Wh (Watt hours), we multiply the solar panel's rating by the solar insolation value. For example, Bangladesh has an insolation value of about 4.5 kWh/m²/day³, so a 75 W_{peak} panel produces about 75 W_{peak} × 4.5 hours = 337Wh per day.

However, the rating is derived from standardized peak tests and in practice is lower due to a range of "loss factors" including temperature (higher temperatures degrade performance); the angle of the panel to the sun; dust (on the panels and in the air); aging of the panels (as solar panels age, their output degrades slightly), and more.

It is beyond the scope of this paper to go into the details of these loss factors which individually range from 3% to 10% or more. Added up, the total loss factor for solar panels can reach 40% and more. Thus, the actual efficiency of the solar panels in real conditions can vary from 55% to 75%. That means, assuming an efficiency of 60%, a 75 W_{peak} panel that under standardized conditions produces 337Wh per day (using solar insolation value of 4.5), actually produces only 337Wh * 60% or about 200Wh per day.

Loss factors must be compensated for when determining the appropriate capacity of a solar power system. Experienced solar installers can advise on applicable loss factors for a particular area.

Design Steps

There are three-main steps in designing a solar deployment: load calculation, system sizing and system design.

In designing a system, we have the most influence on the load; therefore, the following presents the process of providing a load estimate that can be used to approximate a total budget. It is by no means sufficient to accurately design a system. The actual system sizing and design are best left to a solar installer that has knowledge of the local conditions and availability of equipment. In this paper, we have made simplifications, and only highlight some of the important factors that influence the design; system installers may take different approaches in their calculations.

Load Calculation

The first step in the design of the solar deployment is to calculate how much energy your deployment requires. This is the sum of all the items that require energy, how much energy each item consumes, and how long they operate per day. For example, the school in Netrokona wanted to operate ten PCs for six hours per day. As they wanted to operate the lab after darkness, they also wanted to be able to operate a few lights for two hours per day.

The load calculation for the lab is shown in Table 1.

To minimize power consumption, we chose energy efficient netbooks which on average consume about 15W, and for lights, chose 7W compact fluorescent lights. Thus, the total required load was calculated as 942 Wh per day as shown in Table 1.

Table 1. Load calculation for the Netrokana PC lab

LOAD	WATTS PER UNIT	NUMBER OF UNITS	HOURS PER DAY	WATT HOURS PER DAY
Netbook	15	10	6	900
Lights	7	3	2	42
Total Load				942

System Sizing

There are two main factors in system size: the required capacity of the solar panels and the batteries. Once the energy requirement per day is known, we can then proceed to calculate the size of the system.

Solar Panels

Once we know the daily energy requirement, the solar insolation factor for the area that we want to deploy, and the efficiency factor, it is a straight forward calculation to determine the required capacity of the solar panels in W_{peak} .

In this deployment we used a solar insolation factor of 4.5 for Bangladesh. Based on the recommendation of an experienced solar system installer, we used an efficiency factor of 60% to accommodate for temperature, dust, aging, etc. Thus, we need to divide the power requirement (942 Wh) by the efficiency factor (60%) and divide the result by the solar insolation value (4.5) to derive the required peak panel capacity

$$942\text{Wh} / 60\% / 4.5 = 348 W_{peak}$$

Therefore, we require a minimum of $348 W_{peak}$ panel capacity.

Battery

The second step is to determine the battery capacity. As mentioned previously, the power to operate all equipment is actually drawn from the batteries, not directly from the solar panels. In addition, batteries store energy and provide continuous operating hours when the sun is not shining.

The main factor to take into consideration when sizing batteries is the number of "backup days" – that is, the number of days the system can operate without having any electricity generated by the solar panels. In many installations, three days' backup is used. However, the number of backup

days must be balanced against the cost of the system. For this lab, we deemed 1½ days to be sufficient to reduce the overall cost of the system.

The capacity of batteries is rated in ampere-hours (Ah). For example, a 12-volt, 120Ah battery has a total capacity of 1,440 Wh.⁴ However, to preserve the life of a battery⁵ it is advisable to discharge the battery to no more than 30% to 50% of its total capacity. This is known as "depth of discharge." If we want to limit the battery to a depth of discharge of 50%, we have to treat the actual capacity of a battery as half of its rated capacity. Thus, to have 1½ days of backup, the calculation becomes

$$942 \text{ (Wh)} / 50\% \text{ (Depth of Discharge)} * 1.5 \text{ (Backup Days)} = 2,826\text{Wh}$$

Thus, we require 2,826Wh of backup storage or a battery capacity (assuming 12V batteries) of at least $2,826\text{Wh}/12\text{V} = 235\text{Ah}$.

System Design

Once you know the system requirements in terms of solar panel and battery capacity, you can then design the actual system. This consists of deciding the size and quantity of solar panels and the batteries. Several factors influence this decision, such as local availability and price.

Solar panels come in varying sizes and ratings. In our example, we require $348 W_{peak}$ of panel capacity. This can be satisfied by four $100 W_{peak}$ panels, or by six $60 W_{peak}$ panels. Similar, the battery capacity of 235 Ah can be met by connecting two 120Ah batteries.

As these systems involve electrical equipment that can be potentially dangerous, the involvement of an experienced solar installer and electrician is a must. An experienced system installer will also advise on the number and size of charge controllers, wiring sizes, circuit breakers, and other components.

Deployment Considerations

It is also important to design a system that is balanced. For example, the size of the batteries has to be in line with the capacity of the solar panels. Chronic under- or over-charging will damage the batteries and shorten their life time considerably.

There are additional factors to consider for the actual deployments most associated with on the ground local conditions. These include whether to operate an all DC or AC system, the system voltage, the size and number of the charge controller, and so on. In some locations, solar panels also make inviting targets for theft, so security must also be considered. As mentioned, it is best to leave the actual design and installation to an experienced solar installer.

The “Solar Power for PC Deployments: A Deployment Guide” paper by Inveneo discusses these considerations and other factors that can assist solar installers to optimize their systems and support large numbers of PCs in remote areas.

Summary

Dramatic energy efficiency improvements in PC systems have enabled the use of solar power to support deployments of large numbers of PCs in areas that are not connected to the electrical grid. With modern PCs consuming as little as one-tenth the electrical power as systems of a few years ago, it is now more practical than ever for remote schools, community organizations, health centres and other institutions to bring computing capabilities and connectivity to the people who will benefit the most. By considering real requirements and matching them with the right solar power system configuration, it is now possible to deliver clean, solar power at quite a reasonable cost.

Solar Information Boat

Roads are few and watercrafts are the main means of transportation in northern Bangladesh, where Care* Bangladesh has operated four “information boats” for more than a year. The information boats are floating telecenters and offer critical ICT services that were previously not easily available. This includes digital photo services with instant printing, video phone service via Skype*, ICT training, and TV viewing. All of the services are offered at affordable rates and provide an income to the operator.

Initially, electrical power for the services was provided by a small petrol driven generator. However, this proved to be restrictive due to the high cost and limited availability of fuel. This caused the information boats to operate for only one or two hours per day, which severely limited the amount of revenue they could generate for their operators.

Together with Care, Intel designed and implemented a solar power generation system for two of the information boats. This consisted of mounting four 100W_{peak} solar panels on the roof of the boat, which charged four 160 Ah batteries. Furthermore, the facilities in the boat were expanded by adding three power efficient netbooks.

Investing in the new system has created numerous benefits for the entrepreneur running the boats. After several months of operation using solar energy, revenues increased by 30% due to longer operating hours. In addition, operating expenses have been reduced by over US\$75 per month as fuel does not have to be purchased. With the increase in revenue, and the decrease in operating expenses, it is estimated that the solar installation will pay for itself in about 30 months.



Solar Power for PC Deployments: Enabling ICT Beyond the Grid



Rural Solar PC Lab (Mindanao)

The Alliance for Mindanao Off-grid Renewable Energy (AMORE*) Program has provided clean and renewable energy to hundreds of communities and households in Mindanao, Philippines for years. This includes providing electrical power for schools to power a TV for long distance learning using a DVD player or satellite TV. However, the program did not include PCs, which would make for more interactive and richer learning environment.

Intel teamed up with Amore to design a power efficient solar PC lab for Mindanao's Marilog Central Elementary School. Using five Intel® Atom™ processor based netbooks, one ultra low voltage laptop and a 3G Wi-Fi router for local Internet access along with energy efficient lights, they designed a PC lab that consumes only 900 to 1,100 Wh per day. Two 210W_{peak} solar panels, combined with three 100Ah batteries, provide enough energy to power the lab for four to six hours per day.

The authors would like to thank Bob Marsh from Inveneo, and Samuel Baybay and Dave Balleza from Amore (Alliance for Mindanao Off-grid Renewable Energy Program) for their valuable input into the creation of this document.

¹ www.solarbuzz.com/ModulePrices.htm

² The Surface meteorology and Solar Energy website at <http://eosweb.larc.nasa.gov/cgi-bin/sse/sse.cgi?+s01#s01> provides a wealth of data.

³ As insolation values vary over the year, it is common practice to employ insolation conservatively by using the lowest monthly value.

⁴ Ohm's law states Power (Watts) = Voltage (Volts) x Amperage (Amperes)

⁵ The life span of a deep cycle battery varies from 1 -5 years. One of the biggest factors in prolonging battery life span is to limit the depth of the discharge i.e. the amount of power drawn from the batteries each day.

This document and the information given are for the convenience of Intel's customer base and are provided "AS IS" WITH NO WARRANTIES WHATSOEVER, EXPRESS OR IMPLIED, INCLUDING ANY IMPLIED WARRANTY OF MERCHANTABILITY, FITNESS FOR A PARTICULAR PURPOSE, AND NON-INFRINGEMENT OF INTELLECTUAL PROPERTY RIGHTS. Receipt or possession of this document does not grant any license to any of the intellectual property described, displayed, or contained herein. Intel products are not intended for use in medical, life-saving, life-sustaining, critical control, or safety systems, or in nuclear facility applications.

Performance tests and ratings are measured using specific computer systems and/or components and reflect the approximate performance of Intel products as measured by those tests. Any difference in system hardware or software design or configuration may affect actual performance. Intel may make changes to specifications, product descriptions and plans at any time, without notice.

Copyright © 2011 Intel Corporation. All rights reserved. Intel, the Intel logo, Pentium, Atom and Intel Core are trademarks or registered trademarks of Intel Corporation in the United States and other countries.

*Other names and brands may be claimed as the property of others

